



I.S.A. Istrumentazioni Sistemi Automatici S.r.l.
Via Prati Bassi 22 - 21020 Taino (VA) - ITALIA
tel +39 0331 956081 - fax +39 0331 957091
e-mail: isa@isatest.com - www.isatest.com

DATE: 10/08/2013

DOC.SIE10102

REV. 13

**T3000 TEST SET
THE SUBSTATION EQUIPMENT
TEST SET
for testing relays, CT's, PT's
and primary injections**

1 INTRODUCTION	4
2 APPLICABLE STANDARDS	7
3 CHARACTERISTICS	8
3.1 FOREWORD	8
3.2 MAIN GENERATOR	8
3.2.1 High AC current	8
3.2.2 Low AC current	8
3.2.3 Low DC current	9
3.2.4 Current impulses	9
3.2.5 High AC voltage	10
3.2.6 Low AC voltage	10
3.2.7 Other features of main outputs	10
3.3 AUXILIARY AC VOLTAGE	11
3.4 AUXILIARY DC VOLTAGE	13
3.5 AUXILIARY CONTACT	14
3.6 TIMER	14
3.7 OUTPUTS MEASUREMENT	15
3.7.1 Current and voltage	15
3.7.2 Phase angle	17
3.7.3 Other measurements	17
3.8 EXTERNAL INPUTS MEASUREMENT	18
3.8.1 Current measurement	18
3.8.2 Voltage measurement	19
3.8.3 Other measurements	19
3.9 DISPLAY	20
3.10 TEST CONTROL	20
3.10.1 Relay selection	20
3.10.2 Transformers selection	21
3.11 MENU SELECTIONS	21
3.11.1 Relay selection	22
3.11.2 Transformers selection	27
3.12 CONNECTION CABLES	29
3.13 OTHER CHARACTERISTICS	30
3.14 OPTIONS	31
3.14.1 Power supply code PII20102	31
3.14.2 Optional high voltage output 1200 V; codes PII30102(supply 230 V) or PII40102 (supply 110 V)	31
3.14.3 Transit cases	31
3.14.4 Current clamp code PII16102	32
3.14.5 Thermal printer PII14102	33
3.14.6 High I DC module PII13102	33
3.14.7 BU2000 very high current boosters	33
3.14.8 D/1000 differential relay test module, code PII40093	37
3.14.9 FT/1000 current filter, code PII16093	38
3.14.10 Earth resistance and resistivity test kit, code PII19102	38
3.14.11 SH-2003 universal scanning head for T1000 and T3000, code PII43102	39
4 PROTECTIONS	41

1 INTRODUCTION

T3000 is the sole solution for all problems of the test engineer, as it allows performing the test both of all type of relays that can be tested with single-phase faults, and of all tests to be performed on current and voltage transformers. It allows also testing energy meters and transducers.

The table below lists the relays that can be set and tested by T3000.

Type of relay	IEEE code
- Distance (tree sets)	21
- Synchronizing	25
- Thermal	26
- Over/under-voltage	27 - 59
- Power, varmetric or wattmetric	32 - 92
- Under current	37
- Reverse phase current	46
- Instantaneous overcurrent	50
- Ground fault	50N
- Timed overcurrent	51
- Circuit breaker	52
- Power factor	55
- Directional overcurrent	67
- Directional ground fault	67N
- Automatic reclose	79
- Frequency	81<, 81>
- Frequency rate of change	81R
- Motor protection	86
- Differential (with D1000 option)	87
- Directional voltage	91
- Tripping relay	94
- Voltage regulation	
- Timers	

The following table lists the tests that can be performed on CT and VT.

N.	TEST OF	TEST DESCRIPTION
1	CT	Ratio, Voltage mode
2	CT	Ratio, polarity and burden
3	CT	Burden; secondary side
4	CT	Excitation curve
5	CT	Winding or burden resistance
6	CT	Voltage withstand
7	CT	Polarity by impulses
8	VT	Ratio; polarity
9	VT	Burden, secondary side
10	VT	Ratio, electronic transformers
11	VT	Voltage withstand
12	VT	Secondary over-current protection
13	PT	Ratio per TAP
14	PT	Resistance of Tap Changer contacts
15	PT	Tap Changer dynamic resistance test
16	R	Ground resistance and resistivity

Tests are performed in accordance with the following IEC standards: EN 60044-1; EN 60044-2; EN 60044-5; EN 60044-7; EN 60044-8; EN 60076-1, and also in accordance with ANSI/IEEE C57.13.1.

In addition to the above, T3000 can test:

- . Converters: V; I; φ° ; p.f.; W; VAR; f., both 0 to 5 and 4 to 20 mA.
- . Energy meters, single phase.

With external options, T3000 can test:

- . With the High IDC module, up to 400 A: contact resistances, in the micro-Ohm range;
- . With the BU2000 very high current booster option, primary tests up to 4000 A.

The basic T3000 function is to generate current and voltages, as requested by the type of test to be performed, that is selected on the LCD screen by means of the multi-function knob. Test results are kept in memory, and can be transferred to a PC at a later time, along with settings.

The instrument contains three separate generators:

- . Main generator: it has six outputs: High AC current; Low AC current; Low DC current; Current impulses; High AC voltage; Low AC voltage.
- . Auxiliary AC voltage generator. It generates an independent, phase adjustable AC voltage.
- . Auxiliary DC voltage generator, to feed relays under test.

All outputs are adjustable and metered on the large, graphic LCD display. With the multi-purpose knob and the LCD display it is possible to enter the MENU mode, that allows to set many functions, that make T3000 a very powerful testing device, with manual and semi-automatic testing capabilities, and with the possibility to transfer test results to a PC via the RS232 interface. These results can be recorded, displayed and analysed by the powerful TDMS software, which operates with all WINDOWS versions.

The ease of operation has been the first goal of T3000: this is why the LCD is graphic, and so large. With it, the dialogue in MENU mode is made easy. Besides, all T3000 outputs relevant to the selected test are continuously measured, and output values are displayed, with no extra effort to the operator. Also the show waveform feature can be of help: any doubt about strange measurements, distortion and so on can be solved.

Additional features are:

- . Two meters, current and voltage, with independent inputs, and with High and Low inputs each, allow measuring CT or VT outputs or any other source;
- . An auxiliary contact, that follows START and STOP inputs, allows simulating the circuit breaker.

The instrument is housed in a transportable aluminium box, which is provided with removable cover and handles for ease of transportation.

With respect to T/1000, T3000 incorporates the CT, VT and PT tests. Main differences are:

- . Higher AC current generation: up to 800 A;
- . Generation of the high voltage output for the test of the saturation curve: up to 3000 V;
- . The saturation curve can be displayed on the screen; it is printed and stored in the local memory. Afterwards, it can be transferred to a PC with X-PRO3000 for further analysis;
- . Generation of current impulses for the CT and VT polarity test;
- . The DC voltage generation is replaced by the DC current generation;
- . The resistor set is reduced to the most important values for low current adjustment: 1000 Ohm and 220 Ohm;
- . In the measurement section, there is the additional 10 V input;
- . The auxiliary DC and AC voltages can be switched ON/OFF;
- . Emergency push-button;
- . For the 3000 V output, security key.

The following is the list of available options:

1. Power supply 110 V, to be specified at order;
2. Optional high voltage 1200 V instead of 3000 V (better choice for 5 A rated CT's), to be specified at order;
3. Transit cases: moulded plastic or aluminium;
4. Secondary current clamp meter;
5. Local thermal printer;
6. High IDC current generator, up to 400 A DC, for the measurement of contact resistances;
7. BU2000: very high current booster, for currents up to 4000 A AC, for primary injection tests;
8. D/1000, for the test of differential relays, including the harmonic restraint test;
9. FT/1000: filter for highly inductive loads, that tend to distort the current waveform;
10. Cables and electrodes kit for the measurement of plant earth resistance, and soil resistivity;
11. SH-2003: Universal scanning head.

2 APPLICABLE STANDARDS

The test set conforms to the EEC directives regarding Electromagnetic Compatibility and Low Voltage instruments.

A) Electromagnetic Compatibility:

Directive no. 2004/108/EC. Applicable Standard : EN61326-1 + A1 + A2.

EMISSION

- EN 61000-3-2: Harmonic content of power supply. Acceptable limits: basic.
- EN 61000-3-3: Limitation of voltage fluctuations and flicker. Acceptable limits: basic.
- CISPR16 (EN 55011 class A): Limits and measurement methods of radio-electric disturbances for industrial, medical and scientific instruments at radio-electric frequencies.

Acceptable limits for conducted emission:

- . 0.15-0.5 MHz: 79 dB pk; 66 dB avg.
- . 0.5-5 MHz: 73 dB pk; 60 dB avg.
- . 5-30 MHz: 73 dB pk; 60 dB avg.

Acceptable limits for radiated emission:

- . 30-230 MHz: 40 dB (30 m)
- . 230-1000 MHz: 47 dB (30 m)

IMMUNITY

- EN 61000-4-2: Immunity tests for ESD. Test values: 8 kV in air; 4 kV in contact.
- EN 61000-4-3; Immunity tests for radio frequency interference. Test values (f= 900 ± 5 MHz): field 10 V/m, modulated AM 80%; 1 kHz
- EN 61000-4-4; Immunity tests for high speed transients (burst). Test values: 2 kV peak; 5/50 ns.
- EN 61000-4-5; Immunity tests for surge. Test values: 1 kV peak differential mode; 2 kV peak common mode; 1.2/50 us.
- EN 61000-4-6: immunity to low-voltage sinusoidal waveform. Test values: 0.15-80 MHz, 10 Vrms, 80% AM 1 kHz.
- EN 61000-4-8: Immunity tests for low frequency magnetic fields. Test values: 30 Arms/m.
- EN 61000-4-11: Immunity test for power supply drops. Test value: 1 cycle; 100% drop.

B) Low Voltage Directive:

Directive n. 2006/95/EC. Applicable standard, class I instrument, pollution degree 2, Installation category II: CEI EN 61010-1.

In particular, for a pollution degree 2:

- dielectric rigidity 1.4 kV AC, 1 minute. The rigidity is 4600 V AC 1 minute between the high voltage output and the rest of inputs and outputs.
- Inputs/outputs protection: IP 2X, as per IEC69529, for all but high voltage outputs; IP4X for high voltage outputs.
- Operating temperature: 0 to 50 °C; storage: -20 °C to 70 °C.
- Relative humidity : 5 - 95%, without condensing.
- Vibration: IEC 68-2-6 (20 m/s² at 10 – 150 Hz);
- Shock: IEC 68-2-27 (15 g; 11 ms; half-sine).
- Altitude: less than 2000 m.

3 CHARACTERISTICS

3.1 FOREWORD

T3000 incorporates three different generators: the main one and two auxiliary ones. The main generator has six outputs; an auxiliary one generates the AC voltage; the other auxiliary one generates the DC voltage. The high AC voltage can be generated only if it is selected and confirmed by a key.

The main generator is made of a variable transformer followed by a transformer. The variable transformer does not reach the zero position; so, when you are adjusting the output current on a low burden, the minimum current can be up to 5% of the range. If this is a problem, select the 60 VA power: the current is reduced to one fifth.

3.2 MAIN GENERATOR

The main generator has six outputs: High AC current; Low AC current; Low DC current; Current impulses; High AC voltage; Low AC voltage. Output adjustment is performed via a knob. The following specification applies to the separate usage of these outputs.

On all outputs is provided the capability of generating the selected current at maximum power or at reduced power. Reduced power selection eases the current adjustment for modern relays, where the load is negligible.

3.2.1 High AC current

- Output characteristics: see tables below.

1) NOMINAL POWER 600 VA

CURRENT OUTPUT A	OUTPUT POWER VA	MAX. TEST DURATION s	RECOVERY TIME min
100	600	STEADY	-
150	800	15 min	30
200	1000	4 min	15
400	1600	15	5
600	2000	5	3
800	2000	1	2

- Power selection: via menu.

- Connection: two high power sockets, with safety protections.

3.2.2 Low AC current

- Output characteristics: see tables below.

1) NOMINAL POWER 300 VA

RANGE A AC	CURRENT OUTPUT A	OUTPUT POWER VA	MAX. TEST DURATION s	RECOVERY TIME min
---------------	---------------------	--------------------	-------------------------	----------------------

40	12	300	STEADY	-
	18		15 min	30
	24		4 min	15
	36	800	15	5
	48		5	3
	60	1000	1	2
10	5	400	STEADY	-
	7.5		15 min	30
	10	800	60	15
	15		30	10
	20	1000	15	5

2) NOMINAL POWER 60 VA

RANGE A AC	CURRENT OUTPUT A	OUTPUT POWER VA	MAX. TEST DURATION s	RECOVERY TIME s
40	12	60	STEADY	-
	17		10 min	30
	23		60	10
	36		1	2
10	5	60	STEADY	-
	6		10 min	45
	7		60	2
	10		1,5	2

- Power selection: via menu.
- Connection: three high current safety sockets.

3.2.3 Low DC current

- Output characteristics: see table below.

CURRENT OUTPUT A	LOAD RESIST. Ohm	OUTPUT POWER VA	MAX. TEST DURATION min
10	0	0	STEADY
3	2	18	STEADY
1	8	8	STEADY

- Type of DC voltage: unregulated, via diode bridge rectifier and capacitor, plus limiting resistor.
- Power selection: via menu.
- Output connection: two safety sockets.

3.2.4 Current impulses

Current impulses are only positive; this solves the problem of the ambiguity of secondary impulse polarity that is found if a DC voltage is used.

- Type of waveform: R-C discharge; polarity: positive.
- Current range: from 0 to 10 A peak.
- Pulse generation: upon command.
- Output connection: two safety sockets.

3.2.5 High AC voltage

- Type of generator: variable transformer and high voltage transformer.
- The HV output is open if not enabled.
- Output characteristics: see table below.

VOLTAGE OUTPUT V	CURRENT OUTPUT A	OUTPUT POWER VA	MAX. TEST DURATION Min	RECOVERY TIME Min
3000	0.2	600	STEADY	-
2500	0.6	1500	1	18

- Power selection: via menu.
- Output connection: two H.V. safety sockets.

3.2.6 Low AC voltage

- The AC voltage is isolated from the high AC current.
- AC voltage range: 250 V.
- Available power and duty cycle: see table below.
- Connection: two safety banana sockets.

VOLTAGE OUTPUT V	CURRENT OUTPUT A	OUTPUT POWER VA	MAX. TEST DURATION min
250	0.5	125	STEADY
220	1.15	250	3

3.2.7 Other features of main outputs

- Zero crossing control. Main AC outputs are generated and stopped as the output waveform is zero. This implies that in mode ON+TIME the output drops to zero with a delay from 0 to one cycle after STOP is detected.
- Over-current alarm message.
- Thermal protection: by NTC.
- Output adjustment: from less than 5% to 100% of the output.

- Output measurement. The used output is software selected; the selected socket is confirmed by a light.

3.3 AUXILIARY AC VOLTAGE

- The auxiliary AC voltage output, VAC aux, is isolated from the main AC current and voltage.
- Output ranges: 65 – 130 - 260 V.
- Range selection: software driven, by the multi-function knob and LCD display.
- Auxiliary voltage power: 30 VA, continuous duty, at full range; 40 VA for 1 minute. For lower voltages the limiting current is the following.

RANGE V	MAX CURRENT mA
65	500
130	250
260	125

- Output stability: the adjusted voltage drops of 5% maximum from zero load to full load.
- Output adjustment: continuous. For normal tests the voltage is continuously supplied, and the output voltage is adjusted by the dedicated knob.
- Output distortion: 1%.
- Output connection: safety banana sockets.
- ON-OFF switch to enable the output. A light confirms when the output is available.
- Possibility to phase shift the auxiliary AC voltage output with respect to: the mains, the main current and the main AC voltage. The phase angle reference is the auxiliary voltage. Phase shifter characteristics:
 - . Phase angle adjustment: via the multi-function knob.
 - . Phase angle range: from 0° to 360°.
 - . Adjustment resolution: 1° (one degree).

- Possibility to define the pre-fault voltage independently from the fault value. In this mode, the control knob allows to adjust the pre-fault voltage, while the dedicated knob adjusts the fault voltage. Voltage output selection is automatic: pre-fault voltage with test stopped; fault voltage with test started.

The switch from pre-fault to fault values is performed without falling to zero. The main current or voltage are generated as they cross the zero line; the fault auxiliary voltage is generated at the meantime as the main voltage or current (figure 1).

This feature allows testing voltage relays (27-59) or synchronizing relays (25).

**MAIN AC CURRENT
(MAIN AC VOLTAGE)**

AUXILIARY

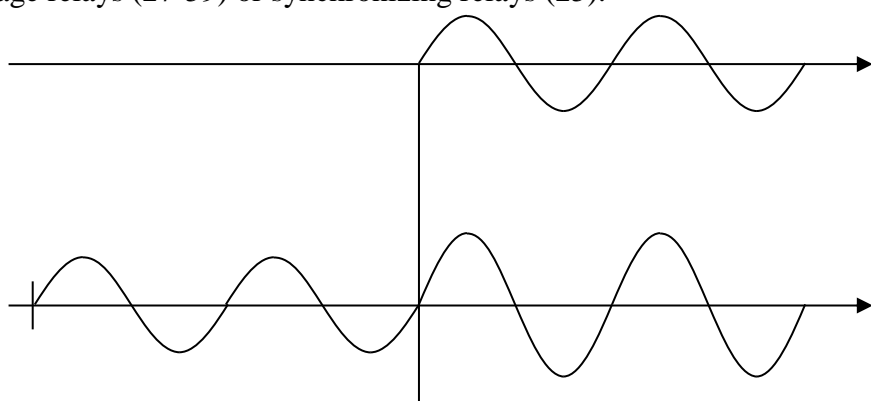

VOLTAGE

TEST START

Figure 1 - Output voltage control

- Possibility to phase shift the pre-fault voltage at an angle independent from the fault voltage. This parameter serves during the test of distance relays, when phase to phase faults are simulated: as test starts, the fault voltage changes amplitude and phase with respect to the pre-fault value (figure 2)

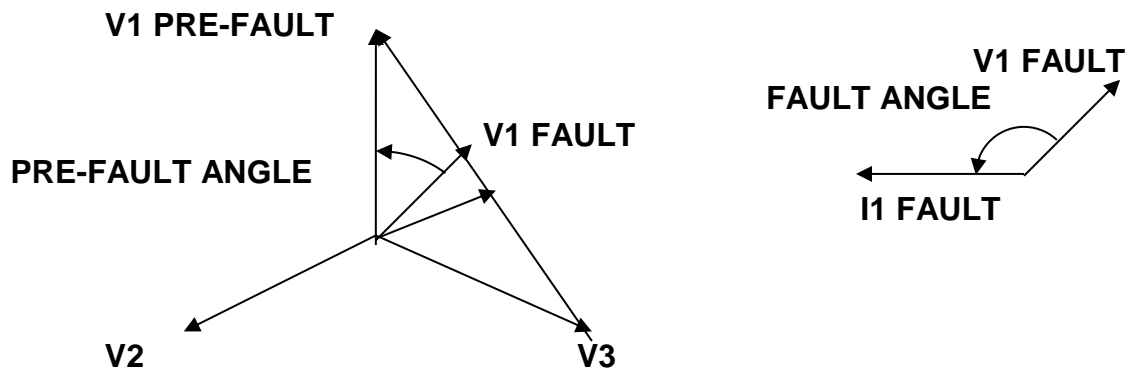
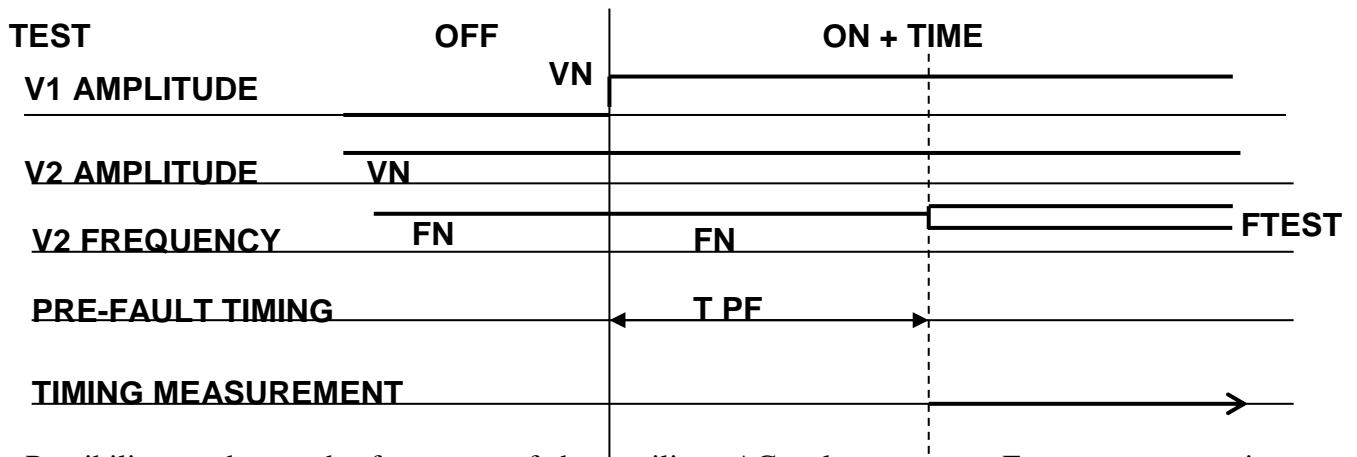

Figure 2 – Pre-fault voltage angle definition

- Possibility to define the duration TPF of pre-fault generation, after test start, prior to generating fault values. This feature is necessary to test synchronization relays: the main output voltage can be applied prior to frequency switching. TPF range: from 0 to 999.99 s.



- Possibility to change the frequency of the auxiliary AC voltage output. Frequency generation characteristics:

- . Frequency range: 40 Hz to 500 Hz.
- . Frequency adjustment: 1 mHz, via control knob.
- . Accuracy: 1 mHz at 50 Hz; 10 mHz at 500 Hz.
- . Possibility to switch from the nominal frequency to the fault one. The nominal frequency is also selectable, independently from the fault.
- . Switching from nominal frequency to fault frequency is performed without altering the output voltage (figure 3).

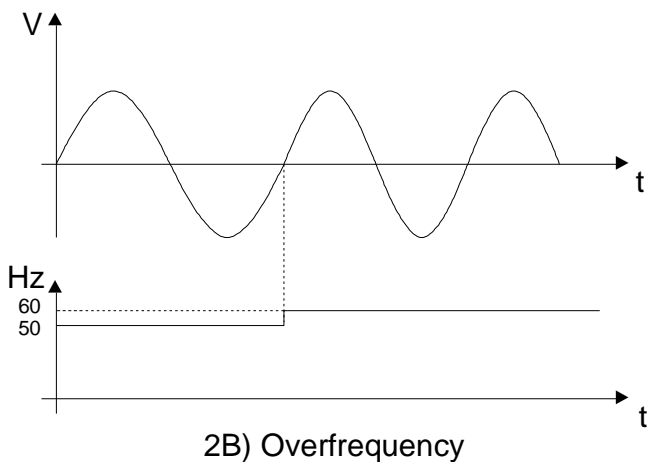
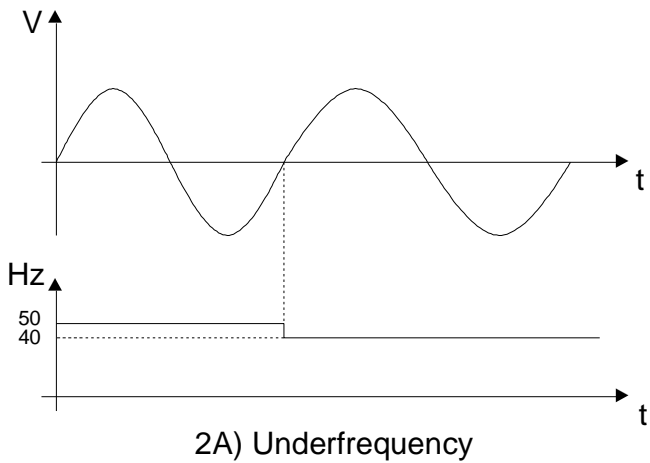

Figure 3 - Frequency relay test waveform

- Possibility to test frequency rate of change relays. Frequency ROC range: from 0.01 Hz/s to 99.99 Hz/s. The frequency change stops at 40 or 70 Hz.

3.4 AUXILIARY DC VOLTAGE

- The auxiliary DC voltage output, VDC aux, is isolated from the main AC current and voltage and from the auxiliary AC voltage output.

- DC voltage ranges: 130 V or 240 V.

- Output adjustment: continuous, by a dedicated knob, from 20 V to the selected range.

- ON-OFF switch to enable the output. A light confirms when the output is available.

- DC voltage power: 90 W at full range, continuous duty, with a current limit of 0.9 A @ 130 V and 0.45 A @ 240 V.

- DC output accuracy:

. For mains supply variations: $\pm 1\%$;

. For load changes: $\pm 1\%$;

. Residual ripple: 1%.

- Output connection: on safety banana sockets.

3.5 AUXILIARY CONTACT

- Possibility to delay the auxiliary contact switch with respect to test start. Delay range: from 0 to 99.99 s.

- Contact range: 5 A; 250 V AC; 120 V DC

3.6 TIMER

The electronic digital timer has a fully automatic start and stop, both for make and break of the input, that can be either a clean contact or a contact under voltage. All selections are menu-driven via the multi-function knob.

- Characteristics of Start and Stop inputs:

.. Inputs do not have any common point, and are isolated from the instrument at 1.4 kV AC;

.. Inputs connection: two banana sockets per input;

.. Inputs may be independently selected as Normal Open or Normal Close;

.. It is also possible to select timer start or stop as the current is injected and timer start/stop on input transition;

.. Selections are displayed on the front panel by 10 dedicated lights;

.. Type of input: either clean or under voltage; selection via the multi-function knob. Maximum input: 250V AC or 275 V DC;

.. For both inputs, when the input is closed or with voltage an LED turns on;

.. When the relay intervenes the TRIP light turns on;

.. Wrong selection protection. If a voltage is applied when the clean input is selected, input circuits are not damaged.

- Input thresholds: when the contact has voltage applied, two thresholds can be selected. The low setting applies to nominal voltage of 24 V; the high setting is from 80 V up.

With voltage

Parameter	Nominal value	Unit
Low setting	12	V DC
High setting	80	V DC

Without voltage

Parameter	Nominal value	Unit
Nominal wetting voltage	24	V
Nominal wetting current	10	mA

- Available measurements:

. Timer start: at test start, or by an external contact;

. Metering of elapsed time between START and STOP.

- Time can be metered as seconds or cycles. Metering range, in seconds: see table.

Range	Resolution	Accuracy
From 0 to 9.999 s	1 ms	$\pm (1 \text{ ms} + 0.005\%)$
From 10.00 to 99.99 s	10 ms	$\pm (10 \text{ ms} + 0.005\%)$
From 100.0 to 999.9 s	100 ms	$\pm (100 \text{ ms} + 0.005\%)$
From 1000 to 9999 s	1 s	$\pm (1 \text{ s} + 0.005\%)$

. Metering range, in cycles, selectable at 50 Hz or at 60 Hz.

Range	Resolution	Accuracy
From 0 to 1,000 (Equal to 19.998 s @ 50 Hz; 16.665 s @ 60 Hz)	0.1 cycles	$\pm (0.1 \text{ cycles} + 0.005\%)$
From 1000 to 499,998.5 cycles @ 50 Hz; From 1000 to 599,998 cycles @ 60 Hz (Equal to 9999 s)	1 cycle	$\pm (1 \text{ cycle} + 0.005\%)$

- Display reset: automatic, at test start.

- Counting mode: this mode is foreseen for the test of energy meters. Maximum input frequency: 10 kHz; voltage threshold can be set as for tripping. It is possible to select this mode via menu, and to set the number of impulses; the test set counts all impulses applied to START input after ON and during all generation, and measures the time elapsed during the count.

3.7 OUTPUTS MEASUREMENT

3.7.1 Current and voltage

- When the test of relay is selected, the following four outputs are displayed at the meantime on the LCD:

- . The selected main output: AC current, or AC voltage, or DC voltage;
- . Auxiliary AC voltage output;
- . Auxiliary DC voltage output;
- . The elapsed test time;
- . The additional measurements, if selected.

OUTPUT	RANGE	RESOLUTION	ACCURACY
HIGH AC CURRENT	19.99 A	20 mA	$\pm (0.5\% + 50 \text{ mA})$
	199.9 A	200 mA	$\pm (0.5\% + 400 \text{ mA})$
	999 A	1 A	$\pm (0.5\% + 1 \text{ A})$
LOW AC CURRENT; 10 A	1.999 A	1 mA	$\pm (0.5\% + 5 \text{ mA})$
	19.99 A	10 mA	$\pm (0.5\% + 20 \text{ mA})$
LOW AC CURRENT; 40 A	7.999 A	4 mA	$\pm (0.5\% + 20 \text{ mA})$
	79.99 A	40 mA	$\pm (0.5\% + 80 \text{ mA})$
VOLTAGE OF LOW AC CURRENT	19.99 V	20 mV	$\pm (0.5\% + 50 \text{ mV})$
	99.9 V	100 mV	$\pm (0.5\% + 200 \text{ mV})$
HIGH AC VOLTAGE; 3000 V	199.9 V	200 mV	$\pm (0.5\% + 0.5 \text{ V})$
	1999 V	2 V	$\pm (0.5\% + 4 \text{ V})$
	2999 V	3 V	$\pm (0.5\% + 6 \text{ V})$
CURRENT OF HIGH AC VOLTAGE	19.99 mA	50 uA	$\pm (0.5\% + 200 \text{ uA})$
	199.9 mA	200 uA	$\pm (0.5\% + 500 \text{ uA})$
	0.999 A	1 mA	$\pm (0.5\% + 2 \text{ mA})$
LOW AC VOLTAGE 250 V AC	19.99 V	20 mV	$\pm (0.5\% + 50 \text{ mV})$
	199.9 V	200 mV	$\pm (0.5\% + 400 \text{ mV})$
	299.9 V	300 mV	$\pm (0.5\% + 600 \text{ mV})$
CURRENT OF LOW	19.99 mA	20 uA	$\pm (0.5\% + 50 \text{ uA})$

AC VOLTAGE	199.9 mA	200 uA	$\pm (0.5\% + 400 \text{ uA})$
	1.999 A	2 mA	$\pm (0.5\% + 4 \text{ mA})$
AUX. AC VOLTAGE 65, 130 V AC	19.99 V	20 mV	$\pm (0.5\% + 50 \text{ mV})$
	199.9 V	200 mV	$\pm (0.5\% + 400 \text{ mV})$
AUX. AC VOLTAGE 260 V AC	19.99 V	20 mV	$\pm (0.5\% + 50 \text{ mV})$
	199.9 V	200 mV	$\pm (0.5\% + 400 \text{ mV})$
	299.9 V	300 mV	$\pm (0.5\% + 600 \text{ mV})$
LOW DC CURRENT	199.9 mA	100 uA	$\pm (0.5\% + 200 \text{ uA})$
	1.999 A	1 mA	$\pm (0.5\% + 2 \text{ mA})$
	19.99 A	10 mA	$\pm (0.5\% + 20 \text{ mA})$
AUXILIARY LOW DC VOLTAGE; 130 V	19.99 V	20 mV	$\pm (0.5\% + 50 \text{ mV})$
	199.9 V	100 mV	$\pm (0.5\% + 200 \text{ mV})$
AUXILIARY LOW DC VOLTAGE; 260 V	19.99 V	20 mV	$\pm (0.5\% + 50 \text{ mV})$
	199.9 V	100 mV	$\pm (0.5\% + 200 \text{ mV})$
	299.9 V	300 mV	$\pm (0.5\% + 600 \text{ mV})$
I IMPULSES	19.9 A	0.1 A	$\pm (5\% + 0.5 \text{ A})$

- When the test of CT or VT or PT is selected, the displayed measurements follow the test selection.

- Type of measurement: true rms for AC outputs; average for DC outputs.

- Readings, resolution and accuracy: see table. Note that the available ranges can be greater than the maximum value of the output to which the load is connected: this means that higher values can be measured without saturation. For example, on the 800 A output the measuring range is up to 999 A. Actually, the test set will not generate more than 800 A, as the test is stopped by the software, that indicates overload, and on the display currents more than 800 A will not be shown.

NOTES:

- When the signal is increased, the range is changed about at the 90% of the range value: this avoids saturation problems when we have to measure fast-changing values.

- Metering temperature coefficient: $\pm 0,05\%/^{\circ}\text{C}$ of the value $\pm 0,02\%/^{\circ}\text{C}$ of the range.

- For relay tests, by menu selections, the metering can also be referred to the nominal current or voltage. In this situation the following applies.

OUTPUT	NOMINAL VALUE RANGE	NOMINAL VALUE STEP	MEASUREMENT RANGE %	RESOLUTION %	ACCURACY %
CURRENT	1 – 999 A	1 A	99.9 999	0.1 1	0.1 1
VOLTAGE AC	1 – 999 V	1 V	99.9 999.9	0.1 1	0.1 1

- Measurement selections: see the MENU paragraph.

3.7.2 Phase angle

- For the relay tests, the auxiliary AC voltage is the reference for the measurement of the phase shift of one of the following parameters:

- . The main current;
- . The main AC voltage;
- . The mains supply.

- For CT or VT tests, the phase angle measurement is automatically selected according to test selection.

- Readings, resolution and accuracy: see table.

MEASUREMENT	RANGE	RESOLUTION	ACCURACY
PHASE	0 - 360	1°	1° ± 1 DIGIT *

* Specified accuracy applies to outputs greater than 10% of the selected range.

- Phase angle temperature coefficient: ± 1 ppM/°C of the value.

3.7.3 Other measurements

Starting from the above measurements, the test set can compute derived measurements; the selection is performed via the control knob for relay tests. For CT or VT tests, the measurement is automatically selected according to test selection.

The following is the list of available measurements. For all of them the following range and resolution applies; the accuracy is the sum of voltage, current and possibly angle accuracy.

PARAMETER RANGE; X IS THE MEASURED ENTITY	RESOLUTION
0 – 999 mX	0,001 X
1.00 – 9.99 X	0,01 X
10.0 – 99.9 X	0,1 X
100 – 999 X	1 X
1.00 – 9.99 kX	10 X
10.0 – 99.9 kX	100 X
100 – 999 kX	1000 X

N.	PARAMETER , AC outputs	DERIVED FROM	FORMULA	UNITS
----	------------------------	--------------	---------	-------

1	ACTIVE POWER, P	I out, VAC 2; φ	$P = I * V * \cos(\varphi)$	W
	REACTIVE POWER, Q	I out, Vac2; φ	$Q = I * V * \sin(\varphi)$	VAr
2	APPARENT POWER, S	I out, VAC 2	$S = I * V$	VA
	POWER FACTOR, p.f.	φ	p.f. = $\cos(\varphi)$	-
3	IMPEDANCE, Z and φ	I out, VAC 2, φ	$Z = V / I$	Ohm, °
4	ACTIVE IMPED. COMPONENT, R	I out, VAC 2; φ	$R = Z * \cos(\varphi)$	Ohm
	REACTIVE IMPEDANCE COMP., X	I out, VAC 2; φ	$X = Z * \sin(\varphi)$	Ohm
5	RATIO, CT or VT or PT	I out, I in or Vout, V in	$R = I \text{ out} / I \text{ in}$ $R = V \text{ out} / V \text{ in}$	-
6	POLARITY, CT or VT or PT	φ I out, I in or φ Vout, V in	OK = $\varphi < 10^\circ$	-
7	BURDEN, CT	Vout; Iout	$VA = I_N^2 * V_{out} / I_{out}$	VA
8	VOLTAGE AND CURRENT KNEES	Vout, Iout	VKm, IKm: values where a 10% increase of V causes a 50% increase of I (see Std)	V, A
9	Resistance	Iout, Vout	$R = V_{out} / I_{out}$	Ohm

For the CT, VT and PT ratio measurement, the following applies.

- Range: 9999;
- Accuracy: 0.5 typical; 1% maximum.

For the polarity test, the phase shift between the two parameters is tested. Answer is OK if phase shift is less than 10° .

For the resistance, the test set measures up to 250 Ohm at 40 mA; the accuracy is: 0.5 typical; 1% maximum.

3.8 EXTERNAL INPUTS MEASUREMENT

- It is possible to meter the current and the voltage of an external (or internal) generator.
- Input connection: by four safety sockets; three for current and two for voltage.
- Metering circuits are isolated between them and from the rest of the instrument.

3.8.1 Current measurement

- Two inputs: 20 mA or 10 A AC.
- Range, resolution, accuracy: see tables below.

RANGE 20 mA	RESOLUTION	ACCURACY
25 mA DC	0.1 mA	$\pm (0.5\% + 0.2 \text{ mA})$

RANGE 10 A	RESOLUTION	ACCURACY
1.999 A AC	1 mA	$\pm (0.5\% + 4 \text{ mA})$
9.99 A AC	10 mA	$\pm (0.5\% + 40 \text{ mA})$

- Metering temperature coefficient: $\pm 0,05\%/^\circ\text{C}$ of the value $\pm 0,02\%/^\circ\text{C}$ of the range.
- Possibility to display the current waveform.

3.8.2 Voltage measurement

- Two inputs: 10 V or 600 V, AC or DC
- Range, resolution and accuracy: see tables below.

RANGE 10 V	CHANGE RANGE	RESOLUTION	ACCURACY
99.99 mV AC/DC	80 mV	0.01 mV	$\pm (0.5\% + 2 \text{ mV})$
9.999 V AC/DC	3 V	2 mV	$\pm (0.5\% + 10 \text{ mV})$
19.99 V AC/DC		10 mV	$\pm (0.5\% + 50 \text{ mV})$

RANGE 600 V	CHANGE RANGE	RESOLUTION	ACCURACY
9.999 V AC/DC	3 V	1 mV	$\pm (0.5\% + 40 \text{ mV})$
199.9 V AC/DC	47 V	50 mV	$\pm (0.5\% + 400 \text{ mV})$
999.9 V AC/DC		300 mV	$\pm (0.5\% + 1000 \text{ mV})$

- Metering temperature coefficient: $\pm 0,05\%/^{\circ}\text{C}$ of the value $\pm 0,02\%/^{\circ}\text{C}$ of the range.
- Possibility to say that the voltage input is a drop across a specified shunt. Shunt range: 1 to 1000 mOhm. In this situation the metering is converted into current, according to the formula:

$$I = V/R_{\text{shunt}}$$
The accuracy is the same as above.
- Possibility to display the voltage waveform.

3.8.3 Other measurements

With relay selection, as per main outputs, it is possible to compute measurements on external inputs. In this instance, measurements available depend upon the AC or DC selection for both inputs (no measurement for mixed selections).

N.	PARAMETER , AC INPUTS	DERIVED FROM	FORMULA	UNITS
1	ACTIVE POWER, P	I _{ext} , V _{ext} ; φ	$P = I * V * \cos(\varphi)$	W
	REACTIVE POWER, Q	I _{ext} , V _{ext} ; φ	$Q = I * V * \sin(\varphi)$	VAr
2	APPARENT POWER, S	I _{ext} , V _{ext}	$S = I * V$	VA
	POWER FACTOR, p.f.	φ	$\text{p.f.} = \cos(\varphi)$	-
3	IMPEDANCE, Z and φ	I _{ext} , V _{ext} , φ	$Z = V/I$	Ohm, $^{\circ}$
4	ACTIVE IMPEDANCE COMP., R	I _{ext} , V _{ext} ; φ	$R = Z * \cos(\varphi)$	Ohm
	REACTIVE IMPEDANCE COMP., X	I _{ext} , V _{ext} ; φ	$X = Z * \sin(\varphi)$	Ohm
5	FREQUENCY, F	V _{ext}	-	Hz
6	PASE ANGLE, IE TO V2	Φ , IE-V2; ref. V2	-	$^{\circ}$
	PASE ANGLE, VE TO V2	Φ , VE-V2; ref. V2	-	$^{\circ}$

The angle measurement accuracy is $\pm 1^{\circ} \pm 1$ digit. This accuracy applies to inputs greater than 10% of the input range, and for frequencies of $50 \pm 0,5$ Hz, and $60 \pm 0,6$ Hz. Temperature coefficient: ± 1 ppm/ $^{\circ}\text{C}$ of the value.

The frequency measurement accuracy is ± 1 mHz ± 1 digit. This accuracy applies to inputs greater than 10% of the input range, and for frequencies of $50 \pm 0,5$ Hz, and $60 \pm 0,6$ Hz. Temperature coefficient: ± 1 ppm/ $^{\circ}\text{C}$ of the value.

For other parameters, the accuracy is the sum of voltage, current and angle accuracies, as applicable.

PARAMETER , DC INPUTS	DERIVED FROM	FORMULA	UNITS
POWER, W	I _{ext} , V _{ext}	$P = I * V$	W
RESISTANCE, R	I _{ext} , V _{ext}	$R = V / I$	Ohm

With CT or VT or PT selection, the measurement follows the selected test.

3.9 DISPLAY

The graphical display has the following main features:

- pixels: 240x128
- backlight color: white
- LCD type: FSTN
- View area: 135x80 mm.

With relay selection, during the standard operation the display shows the measurements of: main AC current (or main AC voltage or main DC voltage, according to selection); auxiliary AC voltage; auxiliary DC voltage; elapsed time. To the left is the area for the access to the menu selection.

With CT or VT or PT selection, input parameters and output measurements follow the selected test.

3.10 TEST CONTROL

3.10.1 Relay selection

- Manual start control:

. OFF: main outputs are not generated; VAC aux is generated, and it can be either the pre-fault value or the fault value, according to selections; VDC aux is generated.

. ON: main outputs are generated; VAC aux has the fault value. In this situation it is possible to verify and memorize the relay threshold, both trip and reset.

. From OFF to ON + time: main outputs are generated and the timer starts according to selections; as STOP is sensed, main outputs are removed and the elapsed time displayed and test result can be memorized.

. From ON to OFF + time: main outputs are removed the timer starts according to selections; as STOP is sensed, the elapsed time is displayed and test result can be memorized.

- Other test control selections:

. Momentary: in ON mode, main outputs are generated until the push-button is pressed;

. Timed: main outputs are generated for the programmed maximum time;

. External. This mode allows for the synchronization of more T3000;

. OFF delay: fault parameters can be maintained for the specified time after relay trips: this allows simulating the circuit breaker delay.

- Reclose test. It is possible to select via menu the test of a reclosing scheme. In this operating mode T3000 automatically applies current with a programmable delay TD after the RECLOSE command is sensed at START input. The test set measures and stores the trip delay and the delay between trip falling edge and RECLOSE trailing edge (see figure 4). Range of TD: from 0 to 999.99 ms. Maximum number of Reclose commands: 49; maximum test duration for all Reclose commands: 9999 s.

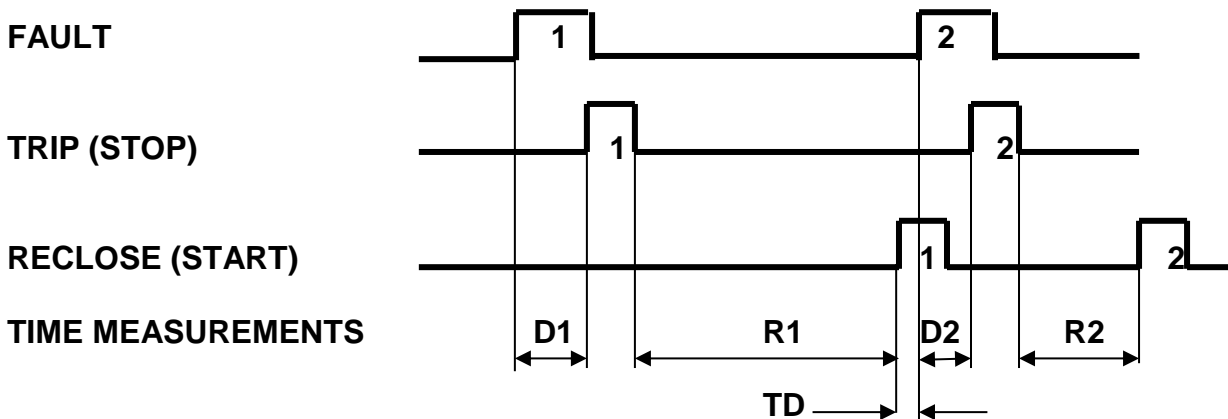

Figure 4: Measure of Delay and Reclose times

- Save selections:
 - . Automatic saving.
 - . Test data can be saved after confirmation. After relay trip, pressing the multi-function knob it is possible to save the test result.

3.10.2 Transformers selection

- The LED by the side of the selected output turns on: this helps the operator not to mistake test connections.
- Test control: by two push-buttons: OFF and ON.
- OFF: all outputs are not generated.
- ON: outputs are generated, according to the selected test. During ON, the selected parameter is adjusted to the desired value. The OK signal blinks 3 s after the parameter did not change any more, and tells the operator that the test is finished. At this moment outputs are cut off, and the operator is warned to set back to zero the adjustment knob.

3.11 MENU SELECTIONS

The following is the list of features that are menu selected. The menu is operated by means of the control knob marked MENU, which incorporates a switch. The menu is entered pressing the knob and selecting the item moving the knob. Once the item has been found and programmed, pressing the arrow the menu moves back of one step, so that other programming can be performed; else, selecting ESC the menu returns to the main window.

The first selection is RELAY or TRANSFORMERS; after this, the corresponding selections are accessible.

Any setting can be saved to and recalled from the memory. Up to 10 settings can be stored and recalled; setting no. 0 is the default one, and pops up at power-on. Settings are permanently stored

in the memory; new settings can be written to the same address after confirmation. For normal mode operation it is possible to recall the standard setting, which cannot be modified.

During the test, test results can be stored in the memory (up to 500 results may be stored). At the end of test, settings and test results can be transmitted to a PC provided with TDMS. The software allows saving test results, examining them and so on. The specification of TDMS is given in a separate document.

When the PC is connected, settings can also be created and transferred into T3000 using TDMS.

3.11.1 Relay selection

During menu selections the display shows output measurements, in reduced format. After confirmation, menu messages disappear, and measurements are displayed in the standard format.

The flux diagram of menu selections can be found in Appendix 1.

LEVEL1	LEVEL 2	LEVEL 3	LEV. 4	FUNCTION
TEST CONTROL	Test mode	Normal (default)		Measures the time delay from START (internal, external) to STOP (internal, external).
		Trip + pulse time		Measures the time delay from START (internal, external) to STOP (internal, external), and the duration of STOP.
		Reclose mode	TD; No. reclose	Two delays are measured: fault to STOP; STOP to START (reclose command). At START, a new fault is generated after TD (0-999.99 s), until the number of reclose (max 49) is reached.
	Fault injection	Maintained (default)		Generation lasts indefinitely
		Momentary		Generation lasts until the ON button is pressed
		External		Generation starts upon reception of the START input: this allows synchronising T/1000.
		Timed	Max time	Generation lasts for the pre-set time duration. Max time 999 s.
		OFF delay	T delay	The main output OFF is delayed by the set amount of time or cycles.
	Output power	300 VA (default) – 60 VA		Selection of full (300 VA) or reduced (60 VA) power
	Save	Don't save (default)		Test data are not saved
		Automatic, at trip		As relay trips data are saved to the next memory location
		Confirm, at trip		As relay trips data can be saved, after confirmation
		Manual		When selected, generated values are saved.
	Auxiliary contact	Timing		Sets the contact timing with respect to test start

LEVEL 1	LEVEL 2	LEVEL 3	LEVEL 4	FUNCTION
TIMER START/ STOP	Start	INT (default)		Timer starts when ON or ON+TIME are activated and outputs generated.
		EXT	NO-NC-EDGE	After ON or ON+TIME, timer starts on the external input. External START input Normally Open, or Normally Closed, or Both (EDGE).
			CLEAN-24 V – 80 V	After ON or ON+TIME, timer starts on the external input. External START input without or with voltage. If with voltage, two voltage thresholds are available: 24 or 80 V.
			COUNT	Timer enters the counting mode; it is possible to program the number of transitions prior to time measurement. After ON or ON+TIME, the test set waits for these transitions before measuring the time.
	Stop	INT		Timer stops when the current of the main generator is interrupted.
		EXT (def.t)	NO-NC-EDGE (def.t)	Timer stops when the STOP input is detected. External STOP input Normally Open or Normally Closed or Both (EDGE).
			CLEAN-24 V – 80 V	Timer stops when the STOP input is detected. External STOP input without or with voltage. If with voltage, two voltage thresholds are available: 24 or 80 V.
			COUNT	Timer enters the counting mode; it is possible to program the number N of transitions to be detected. After ON or ON+TIME, the time from the first valid input to input N+1 is measured; the corresponding energy can be read on the display.
	Timer	s (default)		Time duration metered in seconds
		cycles		Time duration metered in cycles

LEV. 1	LEV. 2	LEV. 3	LEVEL 4	LEVEL 5	FUNCTION		
AUX VAC/ VDC	Aux VAC control	Range			65 (default) ; 130 ; 260 V.		
		Mode	Fault (default)			The auxiliary AC voltage is adjusted by the dedicated knob, and is always present, independently by test start. If the auxiliary voltage should be applied along with the main current or voltage, go to next selection.	
			Prefault + Fault	Prefault Amplitude			Sets the pre-fault auxiliary AC voltage amplitude. Entering this selection in OFF mode the pre-fault voltage is immediately generated: pre-fault voltage is generated and displayed, and adjusted by the multi-function knob . NOTE: the fault voltage is generated pressing ON or ON+TIME, and it is adjusted as usual by the dedicated knob.
				Prefault Phase (0..359°)			Sets the pre-fault auxiliary voltage phase with respect to the fault voltage ; the angle is adjusted by the multi-function knob. The pre-set value is not metered.
			Prefault duration			Sets the duration of the pre-fault auxiliary voltage. When ON or ON+TIME are pressed, the pre-fault will be generated at the mains frequency for the selected duration; then the fault voltage is generated, at the programmed frequency.	
			Prefault frequency			The prefault frequency of the auxiliary voltage may be programmed. The selected frequency is applied when outputs are OFF.	
		Frequency	Locked to mains (default)			If “Locked”, the auxiliary voltage is at the mains frequency.	
			Adjust freq	40-500.000		The frequency of the auxiliary voltage may be programmed. Frequency changes at test start; output voltage does not change in amplitude.	
			Adjust r.o.c.:	± 0.01.. 9.99 Hz/s		The frequency ramps at the programmed rate of Change. The starting frequency can be the mains or the value set by adjust freq.	
		Phase	Locked to mains (default)			With this selection Vaux is in phase with the mains.	
	Adjust phase Vaux - mains			The fault auxiliary voltage can be phase shifted with respect to the mains. The measured angle is displayed. Test must be ON; for a correct angle measurement, the auxiliary voltage must be more than 20% of the range. Phase is adjusted by the multifunction knob.			
	Adjust phase Vaux – I main			The fault auxiliary voltage can be phase shifted with respect to the main current. The measured angle is displayed. Test must be ON; for a correct angle measurement, current and voltage must be more than 20% of the range. Phase is adjusted by the multifunction knob.			
	Adjust phase Vaux – V main			The fault auxiliary voltage can be phase shifted with respect to the main voltage. The measured angle is displayed. Test must be ON; for a correct angle measurement, both voltages must be more than 20% of the range. Phase is adjusted by the multifunction knob.			
	Aux VDC control	Range			130 V (default) or 240 V. If this selection has to be changed, it's necessary to adjust the voltage output to the minimum by the dedicated knob.		

LEVEL 1	LEV. 2	LEVEL 3	LEVEL 4	FUNCTION
METERS	Internal	Units of I	Normal	If selected, current values are displayed in A.
			I/IN	IN
		Units of V	Normal	If selected, voltage values are displayed in V.
			V/VN	VN
	External I	Enabled	AC (default) - DC	With selection AC the meter performs the true rms measurement; with selection DC, the measurement is performed on the average.
			10A – 20 mA	Selects the current input socket
			Waveform	If selected, the current waveform is displayed
	External V	Enabled	AC (default) - DC	With selection AC the meter performs the true rms measurement; with selection DC, the measurement is performed on the average.
			Shunt : 1 – 1000 mOhm	If the voltage is coming from a current dropping on a shunt, specifying the shunt value the current is displayed; default 100 mOhm.
			Waveform	If selected, the voltage waveform is displayed

LEVEL1	LEVEL 2	LEVEL 3	FUNCTION	
METERS (continued)	Other internal	None (default)	No extra measurement displayed	
		Active power	P; W	
		Reactive power	Q; VAr	
		Impedance module	Z, Ohm	
		Impedance argument	$\varphi, ^\circ$	
		Active impedance component	R, Ohm	
		Reactive impedance component	X, Ohm	
		Apparent power	S; VA	
		Power factor	p.f. = $\cos(\varphi V-I)$	
		Active energy (AC)	Ea; Wh	
		Reactive energy (AC)	Er; VArh	
		Other external	None (default)	No extra measurement displayed
			Active power	P; W
	Reactive power (AC)		Q; VAr	
	Impedance module		Z, Ohm	
	Impedance argument		$\varphi, ^\circ$	
	Active impedance component		R, Ohm	
	Reactive impedance component (AC)		X, Ohm	
	Phase, I (AC)		$\varphi, V_{main-Iext}$; reference V_{aux}	
	Phase, V (AC)		$\varphi, V_{main-Vext}$; reference V_{aux}	
	Apparent power (AC)		S; VA	
	Power factor		p.f. = $\cos(\varphi V-I)$	
	Frequency of V (AC)		f, Hz	
	Active energy (AC)		Ea; Wh	
	Reactive energy (AC)	Er; VArh		

LEVEL1	LEVEL 2	LEVEL 3	LEVEL 4	FUNCTION	
RESULTS	Delete			Selected result(s)	
				All results	
CONFIGURATION	Settings	Save to address	1..10	Saves current settings to X	
		Restore address	1..10	Restores settings from X	
		Restore default	1..10	Restores default settings	
	Language	UK, FR, SP, PT, GE, IT		Select the desired language	
	Display	Speed	Slow		The displayed value is refreshed every 1000 ms
			Fast		The displayed value is refreshed every 300 ms
		Hold mode	Hold trip		As relay trips, test data measured 4 periods before trip are held.
			Hold min		As relay trips, the minimum value within 0.5 s is held.
			Hold max		As relay trips, the maximum value within 0.5 s is held.

Note: measurements marked AC apply only if both inputs are selected as alternate current.

3.11.2 Transformers selection

With this selection, the following choice is: CT; VT; Others. After entering the final selection, the operator can input the relevant parameters, still by using the multi-function knob: turning it allows changing the parameter; pressing it makes it possible to go to next parameter.

Once all parameters are set, it is possible to start the test and execute it. Test time is kept to the minimum to avoid the excess of heating.

The following table summarizes all tests and the corresponding performances.

TEST OF	TEST DESCRIPTION	INPUT DATA	CONN. OUT	CONN. IN	MEASUREMENTS
CT N. 1	Ratio Voltage mode	- I primary; - I secondary (nominal values) - Voltage output - Voltage input	High/Low V AC to CT secondary	CT primary to low or high Vin	1) High / Low VAC out; 2) Low V in; 3) Polarity; 4) Actual ratio; 5) Ratio error %; and excitation curve, if selected
CT N. 2	Ratio, polarity and burden	- I primary; - I secondary (nominal values); - Clamp Y/N; - Clamp ratio; - Voltage input.	High I AC to CT primary	CT secondary to high I in; (Low Iin with Clamp); CT secondary to Vin low or high.	1) High I AC out (primary); 2) I in (secondary); 3) Nominal ratio; 4) Actual ratio; 5) Ratio % error; 6) Polarity 7) VA rating 8) Power factor;
CT N. 3	Burden, secondary side	- IN secondary (nominal value); - Voltage input. - Current output	Low I AC to CT burden	CT burden to Vin	1) I out (secondary); 2) V out (secondary); 3) Phase V-I out (secondary); 4) Power factor; 5) VA rating;
CT N. 4	Excitation curve	- Voltage output - I nom secondary - VA rating - Accuracy class - Overload - Internal loss - Standard (IEC, ANSI: see NOTE)	High V AC to CT secondary		1) High V AC out; 2) I out of High V AC; 3) Iout-Vout curve; 4) Current at knee, IKm; 5) Voltage at knee, VKm
CT N. 5	Winding or burden resistance	- Temperature compensation Y/N - Ambient and target temperatures	Low I DC to CT burden or winding	CT burden to Vin	1) Low I DC out; 2) V of lowI DC out; 3) Resistance; 4) Compensated resistance
CT N. 6	Voltage withstand	- Max High V AC ; - Max I test - Tmax	High V AC to: Primary and secondary;		1) High V AC out; 2) I out of High V AC ; 3) Elapsed Time
CT N. 7	Polarity by impulses		Low IDC to CT primary	CT sec. to Iin	1) I DC out; 2) I secondary; 3) Polarity

NOTE: for the excitation curve test, the following standards apply:

1. IEC 60044-1; paragraph 14.4.1. The knee point is the voltage at which the increase of 10% of voltage causes the increase of the 50% of the exciting current.
2. ANSI C57.13.1; chapter 9. When you plot a log-log diagram with the excitation current on the X axis and the exciting voltage on the y axis, the knee point is the one where the tangent of the curve is at 45°.
3. ANSI C57.13.1; chapter 9. When you plot a log-log diagram with the excitation current on the X axis and the exciting voltage on the y axis, the knee point is the one where the tangent of the curve is at 30°.

TEST OF	TEST DESCRIPTION	INPUT DATA	CONN. OUT	CONN. IN	MEASUREMENTS
VT N. 8	Ratio; polarity	V primary in kV; V secondary; Connection LL, LN for primary and secondary (nominal values)	High V AC to VT primary	VT secondary to V in	1) High VAC (primary) 2) V in (secondary); 3) Phase shift ; 4) Actual ratio; 5) Ratio error %; 6) Polarity
VT N. 9	Burden, secondary side	- V secondary (nominal value) - Connection LL, LN - Voltage output - Voltage input	Low V AC to VT burden	VT burden to V in (if enabled)	1) V out (secondary); 2) I out (secondary); 3) Phase V-I ; 4) Power factor; 5) VA rating
VT N. 10	Electronic Voltage Transformers	- V primary; - V secondary; - Connection LL, LN for primary and secondary (nominal values)	High V AC to VT primary	VT secondary to V in	1) High VAC (primary) 2) V in (secondary); 3) Actual ratio; 4) Ratio error %; 5) Polarity
VT N. 11	Voltage withstand	- Max High V AC; - Max I test; - Test duration.	High V AC to Primary and secondary;		1) High V AC out; 2) I out of High V AC ; 3) Elapsed Time
VT N. 12	Over-current protection	- I Trip - Output current	Low I AC to VT protection		1) I out (secondary) 2) I trip
PT N. 13	Ratio per Tap	- V primary in kV; - V secondary; - Connection LL, LN for primary and secondary	High V AC to VT primary	VT secondary to V in	1) High V AC out; 2) I of High V AC; 3) Phase V-I 4) V in; 5) Actual ratio; 6) Ratio error %.
PT N. 14	Resistance of Tap Changer contacts	- Temperature compensation Y/N - Ambient and target temperatures	Low IDC	V in	1) IDC out; 2) V of IDC out; 3) Resistance; 4)Compensated resistance
PT N. 15	Dynamic tap changer test	- Time base - trigger level	Low IDC	V in	1) IDC out; 2) V of IDC out; 3) Resistance; 4) Resistance waveform
R Grid N. 16	Resistance or resistivity of earthing grid	- Output voltage - Input voltage	Low V AC to auxiliary spike	V input from measurement spike(s)	1) Output voltage 2) Output current 3) Input voltage 4) Ground resistance or Ground resistivity

3.12 CONNECTION CABLES

- N. 1 Mains supply cable, 2 m long.
- N. 1 Interface cable for RS232 port.

- N. 2 High current connection cables, 100 sq. mm, 4 m long, for tests up to 800 A. Terminated on one side with an high current male connector and the other side with a high current female connector.
- N. 2 High current connection cables, 100 sq. mm, 0.5 m long, for tests up to 800 A. Terminated on one side with an high current male connector, and on the other side with a clamp.
- N. 2 High voltage connection cables, 4 m long, 5 kV, with earth screen. Terminated on one side with an HV connector, and on the other side with safety banana plugs.
- N. 2 Low current connection cables, 10 sq. mm, 4 m long. Terminated on one side with the high current connector, and on the other side with a 4 mm banana plug.

- N. 2 Low current connection cables, 2.5 sq. mm, 10 m long. Terminated on both sides with a 4 mm banana plug.
- N. 8 Adapters for relay connection. Adapters are 20 cm long, and are terminated on one side with a banana socket and on other side with a pin terminator.
- N. 4 Clamps to connect low voltage or low current or measurements.
- N. 1 Cable for low voltage measurement connection, shielded, 10 m long. Terminated on one side with the measurement connector, and on the other side with two clamps.
- N. 1 Cable for the 600 V measurement connection, shielded, 10 m long. Terminated on one side with three 4 mm banana plugs, and on the other side with two clamps.
- N. 1 Grounding cable, 8 m long, terminated on one side with a 4 mm banana plug, and on the other side with an earth connection clamp.
- N. 6 Cables 2 meters long, terminated on both sides with banana plugs. Colours Black.
- N. 2 Cables 2 meters long, terminated on both sides with banana plugs. Colours Blue.
- N. 4 Cables 2 meters long, terminated on both sides with banana plugs. Colours Red.
- N. 4 Crocodile Clamps (2 black and 2 red).
- N. 1 Connection Cables Transport case.

3.13 OTHER CHARACTERISTICS

- Interface: serial RS232; baud rate 57600 baud
- Mains supply: 230 V \pm 15%; 50-60 Hz, OR 110 V \pm 15%; 50-60 Hz; to be specified at order.
- Maximum supply current: 16 A.
- The instrument comes complete with the following items:
 - . User's manual;
 - . Spare fuses (no. 5), T16A;
 - . Set of connection cables.
- Dimensions: 455 (W) * 325 (D) * 290 (H) mm.
- Weight: 34 kg.

3.14 OPTIONS

3.14.1 Power supply code PII20102

This option is to be specified at order.

- Mains supply: 110 V ± 15%; 50-60 Hz.
- Maximum supply current: 16 A.

With this power supply voltage, the high current maximum output power is limited as shown in the following table.

CURRENT OUTPUT A	OUTPUT POWER VA	LOAD TIME s	RECOVERY TIME min
100	600	STEADY	-
150	800	15 min	30
200	1000	4 min	15
250	1300	2 min	5
300	1500	1 min	5

Other output characteristics do not change with the power supply.

NOTE: the 110 V supply changes also the characteristics of the BU2000 option: see the description for details.

3.14.2 Optional high voltage output 1200 V; codes PII30102(supply 230 V) or PII40102 (supply 110 V)

The high voltage generator has the main purpose to allow testing the CT saturation knee. The test voltage depends upon the following CT parameters:

- . VA: Nominal CT VA rating;
- . KN: overload factor;
- . IS nominal secondary current.

From this, the saturation voltage can be roughly computed, as follows:

$$VSM = VA * KN / IS$$

If $VSM < 600$ V (typical case for $IS = 5$ A), the use of the 1200 V option gives an higher test current than the standard 3000 V option. In this instance, the characteristics are the followings. This option is to be specified at order.

VOLTAGE OUTPUT V	CURRENT OUTPUT A	OUTPUT POWER VA	LOAD TIME Min	RECOVERY TIME min
1200	0.5	600	STEADY	-
1000	1.5	1500	5	20

3.14.3 Transit cases

Two types of transit cases are available: molded and aluminum.

3.14.3.1 Molded case; code PII24102

The protection of T3000 from delivery problems is provided by this robust transit case, that features the following.

- Molded-case construction;
- Handle on the top and on the side;
- Wheels;
- Dimensions: 450 x 550 x 850 mm ;
- Weight : 15 kg.



3.14.3.2 Aluminum case; code PII17102

In alternative to the above, it is possible to use the following aluminum case, that is lighter and smaller.

- Aluminum metal sheet construction;
- Handles on the side;
- Wheels;
- Dimensions: 400 x 370 x 660 mm ;
- Weight : 11.5 kg.



3.14.4 Current clamp code PII16102

The current clamp allows to avoid the opening the secondary current circuit when performing the primary test of CT burden. The clamp ratio is 1000//1; maximum primary current 100 A; maximum cable diameter 12 mm.

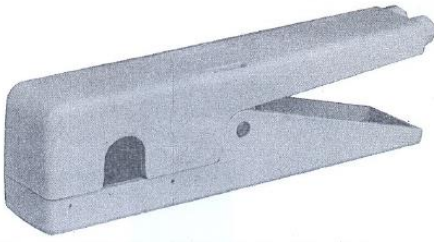

3.14.5 Thermal printer PII14102

Thermal printer, for the printout of the V-I curve in the CT saturation test. Paper 112 mm wide.

3.14.6 High I DC module PII13102

The high DC current module allows the measurement of the low contact resistance of high voltage breakers or of joints. The option is connected to the high AC current output of T3000; the current measurement is connected to the low DC current measurement input; the drop voltage is connected to the low voltage measurement input. DC current output is: 100 A steady; 200 A for 4 minutes; 400 A for 15 s.

The selection of this function is performed via menu; the screen displays: test current; joint voltage; contact resistance. Resistance measurement ranges: 100.0 uOhm, 1.000, 10.00, 100.0 mOhm; 1.000 Ohm, auto-ranging. The option includes two connection cables, with the following characteristics. Measurement accuracy is summarized in the following table.

RANGE	100.0 uOhm	1.000 mOhm	10.00 mOhm	100.0 mOhm	1000 mOhm
ERROR	± 2% ± 2 uOhm	± 2% ± 10 uOhm	± 2% ± 100 uOhm	± 2% ± 1 mOhm	± 2% ± 10 mOhm

N. 2 High current connection cables, 100 sq. mm, 1 m long, for the connection to T3000. Terminated on both sides with an high current connectors, M+F.

The option applies only for power supply of 230 V.

Dimensions: 285 mm (D) x 325 mm (W) x 295 mm (H) ; weight 20 kg.

3.14.7 BU2000 very high current boosters

The very high current booster option allows performing high current primary tests with currents up to 4000 A.

The very high current booster is designed to generate the current while over-loading the generator; its configuration changes according to the desired current value and duration. The option is made of two modules:

- . Transformers BU2000 MAIN and BU2000 AUX: they include the connection cable to the CT and the clamps;
- . BU2000 INTERPOSING MODULE.

The BU2000 MAIN transformer is used in all versions; the number of BU2000 AUX transformers can be selected as a function of the desired test current and/or test duration. In case of a single transformer the interposing module is not necessary.

The option is designed around the concept to avoid wasting power on the connection cables, by putting the power transformers as close as possible to the test object. This approach is particularly useful when the test is performed on CT's in the field, that are from 5 to 10 meters above the ground. The solution is sound because the weight of transformer plus cable plus clamps is comparable to the weight of the connection cables. The highest the test current the biggest the weight of the transformers, but also the biggest the weight of the connection cables. With this solution, the connection cable to the power source is much lighter, does not pose any major problem of voltage drop, and can be any length.

The following sketch shows the connections between T3000, the BU2000 INTERPOSING MODULE and the transformers (up to 4).

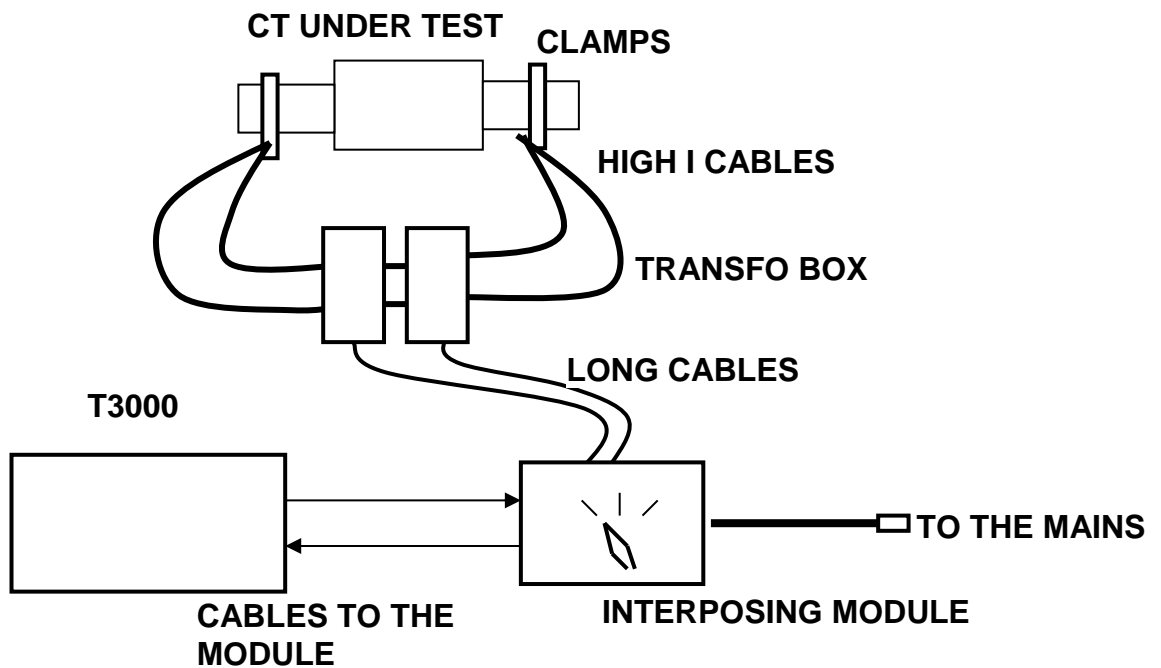

The first transformer BU2000 MAIN has two connection cables: one with the supply, the other one with the output current measurement. The other transformers, BU2000 AUX, have only the supply cable. All cables are 20 m long.

Connections from T3000 to the BU2000 INTERPOSING MODULE are:

- . The variable AC voltage output (not isolated from the mains), that performs the fine current adjustment;
- . The TEST START command, coming from the auxiliary output;
- . The TIMER START contact;
- . The mains supply.

The following table summarizes the available configurations and the corresponding performances.

CODE	N. OF TRANS.	INTERP. MODULE	WEIGHT	N. OF TURNS	TEST CURRENT A	SUPPLY CURRENT A	ON DURATION s
PII50102	1	NO	19.5	3	1000	2.63	INFINITE
					2000	20.96	9
PII51102	2	YES	29.5	2	1000	5	INFINITE
					2000	20	100
					3000	45	6
PII52102	4	YES	49.5	2	1000	5.2	INFINITE

					2000	21	1000
					3000	47	100
					4000	83	9
			1		1000	4.5	INFINITE
					2000	18	1000
					3000	54	50

The table lists:

- . The option code;
- . The number of transformers of the option;
- . The need of the interposing module;
- . The weight to be lifted, that includes: transformers, high current connection cable and connection clamps;
- . The number of turns at the secondary side of the transformers. In the instance of four transformers, it is possible to have 1 or 2 4 turns, according to the desired test current and test duration;
- . The test current;
- . The supply current from the mains;
- . The test duration, that is followed by a pause lasting 3 minutes (or a fraction proportional to the TON/TMAX ratio).

The following table is the same as the above, but it summarizes the test duration as a function of the test current with the different number of transformers; in brackets the number of turns.

MODEL	1 (3)	2 (2)	4 (1)	4 (2)
1000 A	INF	INF	INF	INF
2000 A	9	100	1000	1000
3000 A	-	6	50	100
4000 A	-	-	-	9

Above characteristics apply for power supply of 230 V. For the power supply of 115 V, with the optional T2000 model code PII20110, codes are different, and performances are as follows. Performance reduction follows the limitation to the supply current.

CODE	N. OF TRANS.	INTERP. MODULE	WEIGHT	N. OF TURNS	TEST CURRENT A	SUPPLY CURRENT A	ON DURATION s
PII57102	1	NO	19.5	3	1000	5.3	INFINITE
					2000	42	9
PII58102	2	YES	29.5	2	1000	10.2	INFINITE
					2000	40.5	100
					2500	63	30
PII59102	4	YES	49.5	1	1000	10,5	INFINITE
					2000	41	1000
					3000	80	100

Characteristics of the BU2000 INTERPOSING MODULE:

- Mains connection: by a 64 A rated connector.
- Power-on: by means of a circuit breaker rated 63 A.
- Coarse current adjustment: by means of a four-position selector switch.
- Connections to T3000: power supply cord; Variable voltage output; auxiliary contact, timer START input.
- Capable to drive up to four transformers.
- Weight: 5 kg;

- Dimensions: 33 x 30 x 20 cm (WHD).

NOTE: in case of one transformer, the BU2000 INTERPOSING MODULE is not necessary.

Characteristics of the output transformers: two types.

Type BU2000 MAIN:

- Supply voltage: 230 V (optional 115 V).
- Voltage output (one turn): 0,91 V.
- Steady power: 1000 VA.
- Weight: 11 kg.
- Dimensions: external diameter 190 mm; height 120 mm.
- Connection of the transformer: by a cable, 20 m long, terminated with connectors on both sides.
- Output current metering: by a current transformer with ratio 1000//1. Accuracy class: 0.5%.
- Connection of the CT: by a cable, 20 m long, that includes a shunt, rated 0.1 Ohm 25W, accuracy 0.1%. The cable is terminated with a connector for the connection to the 10 V input of T2000-T3000.

Type BU2000 AUX:

- Supply voltage: 230 V (optional 115 V).
- Voltage output (one turn): 0,89 V.
- Steady power: 1000 VA.
- Weight: 10 kg.
- Dimensions: external diameter 190 mm; height 120 mm.
- Connection of the transformer: by a cable, 20 m long, terminated with connectors on both sides.

Each option is provided with a connection cable having the following characteristics:

- Number of conductors: 2.
- Conductors cross section: 95 sq. mm.
- Conductors type: high flexibility.
- Conductors length: 2.8 m.
- Weight, including the screw-driven clamps: 8.5 kg.

Each option is also provided with two high current screw-driven clamps for the connection to high bars, having the following characteristics:

- Material: aluminium.
- Opening range: from 5 to 60 mm.
- Short-circuit current rating: 41 kA / 1 s.
- Applicable standard: EN 61230.
- Hole to lift the clamp on the conductor, and ring to screw it up.

The screw-driven clamp is shown in the following picture.

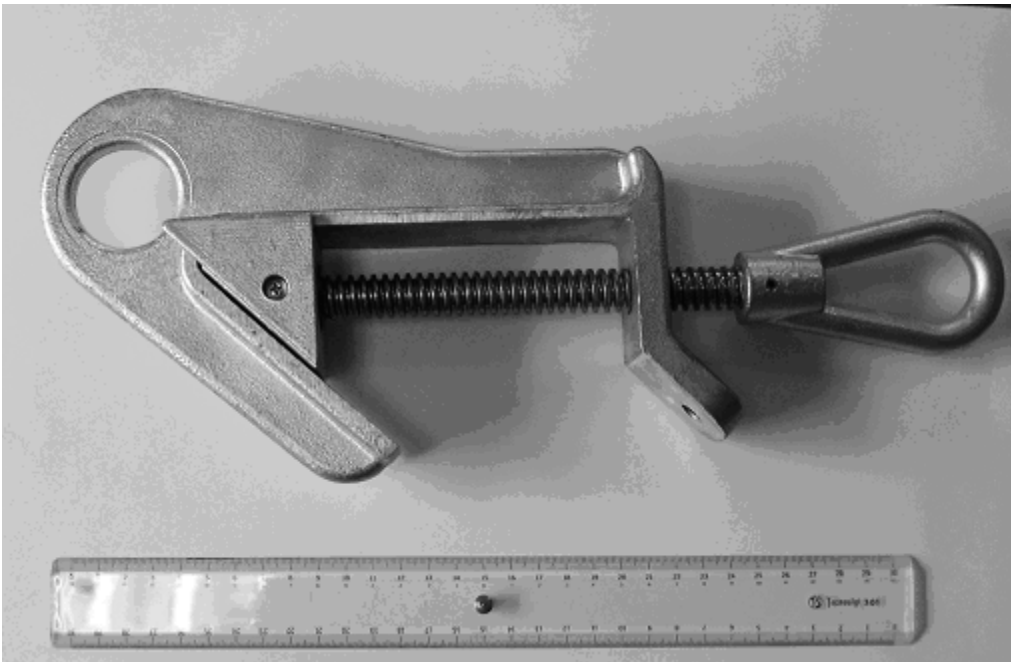

Each option is also provided with four high current clamps for the connection to bars located into narrow places, having the following characteristics:

- Material: iron (bronze for the contacts).
- Opening range: up to 60 mm.
- Steady current rating: 800 A / 1 s.

The spring clamp is shown in the following picture.



Additional options: heavy duty plastic transport case.

The code PII55102 applies to options codes PII50102 and PII57102 (2000 A);

The codes PII55102 and PII56102 apply to options codes PII51102, PII52102, PII58102 and PII5102 (higher currents).

3.14.8 D/1000 differential relay test module, code PII40093

The differential D/1000 differential relay test module allows for the test of the differential relay curve, and also of the harmonic restraint characteristic. The module performances are the followings.

- Input: from the test set auxiliary AC voltage output.
- Output: 0 to 5 A CA.
- Output power: 5 VA, that corresponds to a maximum load of 0,2 Ohm.
- Connection: the output current is connected in parallel to one relay branch, in order to make the differential current.
- Harmonic restraint test: the frequency range is 50 Hz to 500 Hz.
- Output current measurement: connected to the test set external measurement.
- Dimensions: 285 mm (D) x 325 mm (W) x 295 mm (H) ; weight 6 kg.

3.14.9 FT/1000 current filter, code PII16093

The filter unit type FT/1000 is an option to be used with the T/X000 relay test sets. It is connected in series to the relay under test, and guarantees a sinusoidal waveform also when testing current relays with reverse time characteristics, or with heavily saturating burdens, that tend to distort the current waveform.

- Current input ranges: 10 - 40 - 100 - 250 A, on terminal bushings.
- Maximum power yield: 800 VA.
- Filter burden: less than 200 VA at 200 A. The burden is proportional to the range (50 VA at 50 A).
- Service: 50 A continuous service; 200 A for 30 s.
- Selection of the mains frequency: 50 or 60 Hz, by switch.
- Overall dimensions: 220 x 250 x 310 mm.
- Weight: 15 kg.

The following is the FT1000 front panel.

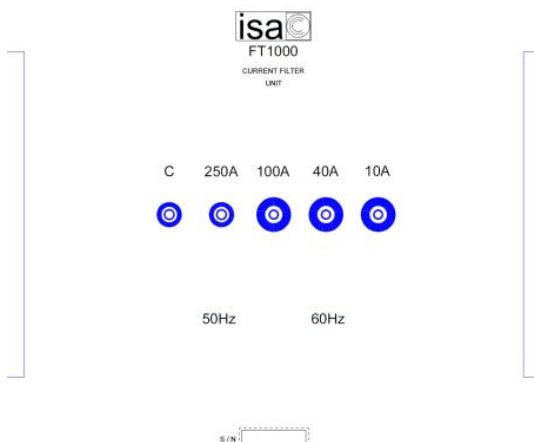

3.14.10 Earth resistance and resistivity test kit, code PII19102

The test of earth resistance and resistivity is included in T3000 as a standard feature. The option is referred to the kit of connection cables and auxiliary spikes that allows executing these tests; it is optional because not all of our customers perform the tests.

The kit is made of the following devices.

A) Current generation.

- One cable for the connection of T3000 to the auxiliary spike, 100 m long, 2.5 sq. mm cross section, wound on a wheel. Terminated with a safety banana connector for the connection to the auxiliary spike, and with a safety socket for the connection to T3000.
- Three cables for the following connections: of T3000 to the above wheel, of the two earth spikes between them, and of the measurement input to the measurement wheel; 4 m long, 2.5 sq. mm cross section. Terminated on both sides with a safety banana connector.
- Two cables for the connections of T3000 to the local earth system, both for generation and measurement, 10 m long, 2.5 sq. mm cross section. Terminated on both sides with a safety banana connector.
- Two auxiliary earth spikes, screw shaped, for the dispersion of the current into the soil. Length: 0.95 m; screwed section 0.6 m. Material: zinc-plated iron. Complete with socket for the connection to the generator.
- Handle to screw the spike into the ground.
- One current clamp to connect T3000 to the local earth system.

B) Voltage measurement

- One cable for the connection of T3000 to one voltage spike, 50 m long, 2,5 sq. mm cross section, wound on a wheel. Terminated with a safety banana connector for the connection to the voltage spike, and with a safety socket for the connection to T3000.
- Two auxiliary earth spikes, to measure the voltage drop; material: zinc-plated iron; length: 0.5 m. Complete with connector for the measurement cable.
- One measurement clamp to connect T3000 to the local earth system.

3.14.11 SH-2003 universal scanning head for T1000 and T3000, code PII43102

SHA-1000 is a scanning head that eases the test of energy meters. It is an universal scanning head because it can be used both with LED impulse electronic meters and Ferraris rotating disk meters; selection is performed via a switch located on the scanning head. In addition to this, a knob allows to adjust the sensitivity of the head.

With rotating disk the sensor uses a green light beam that optimizes the recognition of any type of mark.

With LED recognition the following specification applies:

- . Impulse duration: more than 60 us;
- . With an LED signal having a space ratio 1:2, the frequency must be less than 500 Hz.;
- . Light wavelength: 500 to 960 nm (red: green and blue ARE NOT detected).

The option includes:

- The support that allows to keep the scanning head in front of the energy meter: maximum height 175 mm;
- The cable, 2 m long, from the scanning head to T1000 or T3000;
- The power supply transformer, for the power of 220 Vac, to supply the scanning head.
- Two safety banana plugs for the connection to T1000 or T3000.

Specifications:

- Supply voltage: 11 to 30 V DC;
- Maximum current consumption: 30 mA, with disk mark scanning; 5 mA with LED scanning;
- Output impedance: 470 Ohm;
- Output voltage: from 9.5 to 28.5 V;
- Connection: GND left connection; impulse central connection; DC supply left connection;

- Housing: hard plastic;
- Weight: 30 g;
- Dimensions: 54 (w) x 40 (h) x 35 (d).

4 PROTECTIONS

- If the test set is not connected to the ground, the test set does not allow for power generation, and warns the operator with a diagnostic message.
- Fuse on the mains supply.
- At power-on, a diagnostic sequence controls:
 - . Key microprocessor board components;
 - . Auxiliary supply voltages.If something is wrong, the operator is alerted by a message.
- Emergency pushbutton: if pressed, all main outputs are removed.
- The high voltage output has the following protections:
 - . Confirmation key: if not turned, the HV output is not generated;
 - . The HV is generated only if selected; the HV selection is confirmed by warning lights;
 - . It is impossible to start generating the HV unless the adjustment knob is at zero.
 - . The generation is permitted only until the generation button is kept pressed: if released, the generation is stopped.
- Thermal (NTC) sensor on the main and auxiliary transformers. In case of over-temperature, an alarm message is displayed.
- Thermal sensor on the electronic switch (SCR) that controls current injection, and of the internal temperature. In case of over-temperature, an alarm message is displayed.
- If maximum current limits and time duration of power transformer generators are trespassed, the generation is interrupted, and the operator is warned by an alarm message. Note that the HV protection acts independently on the microprocessor and on the circuit breaker that connects outputs: in case of microprocessor problems, the output cut-off is ensured.
- The DC current source is protected against over-voltages. In addition, the output is automatically kept to zero as test stops, so that any residual energy on the external load is discharged.
- The auxiliary AC voltage is protected by an electronic circuit that stops the voltage generation and opens the connection to outputs socket in case of overload (short circuit included). In case of intervention, an alarm message is displayed. Via the control knob the operator can reset the alarm and close the relay to restore operation.

The auxiliary AC voltage is also protected by a thermo switch that intervenes in case of over-heating. In case of intervention, an alarm message is displayed.
- The DC voltage generator is protected by a current limiter. The user notices the low voltage and removes the overload. The fuse protects the case of counter-feed.
- Re-triggering fuse on the auxiliary contact.
- Timer inputs are protected against wrong selections. If the voltage free input is selected and a voltage is applied less than 250 V AC or 275 V DC, circuits will not be damaged.
- Trip inputs and the auxiliary relay contacts are protected by devices rated 380 V AC, which limit the maximum voltage between sockets and among sockets and ground. The same protection is applied to the AC voltage 2 source, and to the DC voltage source.

- The 20 mA measurement input is protected by a fuse against wrong connections.